



Marvel

Manufacturing Company

40 North 2nd Street
Stroudsburg, PA 18360 USA
570-421-6221

Main Rotor Hub & Blade Assembly Balance Bell Helicopter Model 412 Typical

Balance Equipment

Balance Indicator

1	7BAL052	Kit – Balance Indicator
1	3350	Stand & Hoist

Alternate

1	7BAL051	Kit – Balance Indicator
---	---------	-------------------------

Rotor Hub Mount

1	7HEL092	Kit – Main Rotor Balance Adapter
1	2337	Fixture

Preparation

1. Select a draft free area of adequate size. If required, provide shop equipment for work support and hoist.
2. Assemble 3350 Stand & Hoist and install 7BAL052 Kit under its table section.
3. Prepare 2293 Balance Indicator Arbor for use. Stand upright and remove rubber seals (2) for damping oil at indicator collar and clean indicator surfaces. Reposition indicator collar to provide minimum free clearance, approximately .005 with end of arbor and secure. Maintain arbor in upright position after removal of seals. Reinstall after use if arbor is to be stored horizontally.
4. Clean cone seat of rotor hub. Check for and remove raised portion of nicks. Lightly oil cone surfaces.

Balance Procedure

1. Place 2337 Fixture central on table of work stand and install 3528 Cone, large end downward, over top extension and engage with lower diameter. Lightly tighten set screws to secure.
2. Carefully install rotor hub to seat on cone surfaces. Visually centralize upper bore of hub with fixture extension before releasing hoist.
3. Install 3530 Cone, large end upward, on lower end of 2293 Arbor and position to align its top surface at the arbor scale Sensitivity Setting indicated for the hub by the Installation Illustration. Secure with both set screws.
4. Insert arbor, with cone, downward thru hub fixture to seat cone surfaces.
5. Select and install spacer on exposed lower end of arbor to extend beyond arbor but not to exceed 1 ¼". Insert 2215 hand wheel and tighten to seat cones.
6. Attach 2264 Cable with 2266 Quick Disconnect to arbor and engage ball with lift plate of stand hoist or alternate 2994 Quick Disconnect Cable to shop hoist.
7. Locate latch arms of expandable blade bolts at 90° to the blade axis and latch. Maintain position during all balance operations.
8. Hoist assembly approximately ¼" above stand table, stabilize movements and observe balance condition as indicated by exposure of black disc in top surface of arbor shaft. Check to insure indications are not affected by interferences, air drafts or movement of nearby personnel.
9. Refer to applicable Helicopter Maintenance Manual for Balance Tolerance, method of correction or other assembly requirement. Correct hub to a minimum of unbalance by placing temporary weights on attachment points at the yoke tips. Weigh and enter amounts and locations as "Hub" on applicable Balance Record Form of this instruction. Temporarily attach weights to yoke with cord or safety wire.

Note: Separate forms are provided for hubs having a single, trailing, attachment location on each yoke arm and for those having both leading and trailing locations.
10. Lower to rest on table and stabilize with light hoist load on the cable.
11. Select blade pair for upper yoke and spindle and install. Insert blade bolts with latch arm at 90° to blade axis. Check latch force and adjust if required.

Note: During blade installation, control blades to minimize hub tip and resulting strain on indicator arbor.
12. Reposition 3530 Cone on arbor to align its top surface at arbor scale Sensitivity Setting indicated for the upper blade pair by the Installation Illustration and secure with both set screws. Check spacer on lower end of arbor to insure it extends beyond the arbor but not to exceed 1 ¼". Reinstall hand wheel and tighten seat cones.

13. Hoist assembly approximately $\frac{1}{4}$ " above standard table, stabilize movements and observe balance condition indicated. Check to insure indications are not affected by interferences, air drafts or movement of nearby personnel.
14. Balance correction for the blade pair is made for spanwise balance only. Divide added weight equally between the leading and trailing attachment points for yokes with this provision or place all weight at the single trailing location for yokes of this type. Compensate for indicated chordwise unbalance by placing temporary weights on the damper bridge of a lower spindle. Locate on its upper surface 4" from the trailing bolt center.
15. After balance correction, identify the yoke arm and weight amount added for chordwise compensation. Enter as "Bridge" on the Record Form and remove this weight. Enter the amount of weight and location of each spanwise correction as "Blade" on the form and temporarily attach with cord or safety wire.
16. Remove blade pair and replace bolts in their original positions. Install lower blade pair in the lower position following the procedure of previous step 11.
17. Repeat procedure of step 12 except position cone at Sensitivity Setting specified for the lower blade pair.
18. Repeat procedure of step 13.
19. Repeat procedure of step 14 except place temporary chordwise compensation weight in a like location on the damper bridge of an upper spindle.
20. Repeat procedure of step 15.
21. With reference to the Record Form for rotors having 8 correction weight attachment points, determine final balance weights and locations by totaling entries at each location and record as "Total." Simplify for installation by combining weight amounts which are located opposite and record remaining as "Install". Refer to Balance Record illustration for typical entry.

With reference to the Record Form for rotors having 4 correction weight attachment points, determine final balance weights and locations by applying 98% of each spanwise blade correction to that blade and 15% to the adjacent leading blade. Total entries at each location and record as "Total". Simplify for installation by combining weight amounts which are located opposite and record remaining as "Install". Refer to Balance Record illustration for typical entry.

22. Select combinations of approved balance weights and attaching bolts to equal final weights determined in Step 21 and install on rotor.

**Balancer Installation - Main Rotor
Bell Model 412 Typical**

Hub 11 1/2
 Blade Pair - Upper 12 3/4
 Blade Pair - Lower 14 -
 Sensitivity Setting Reference

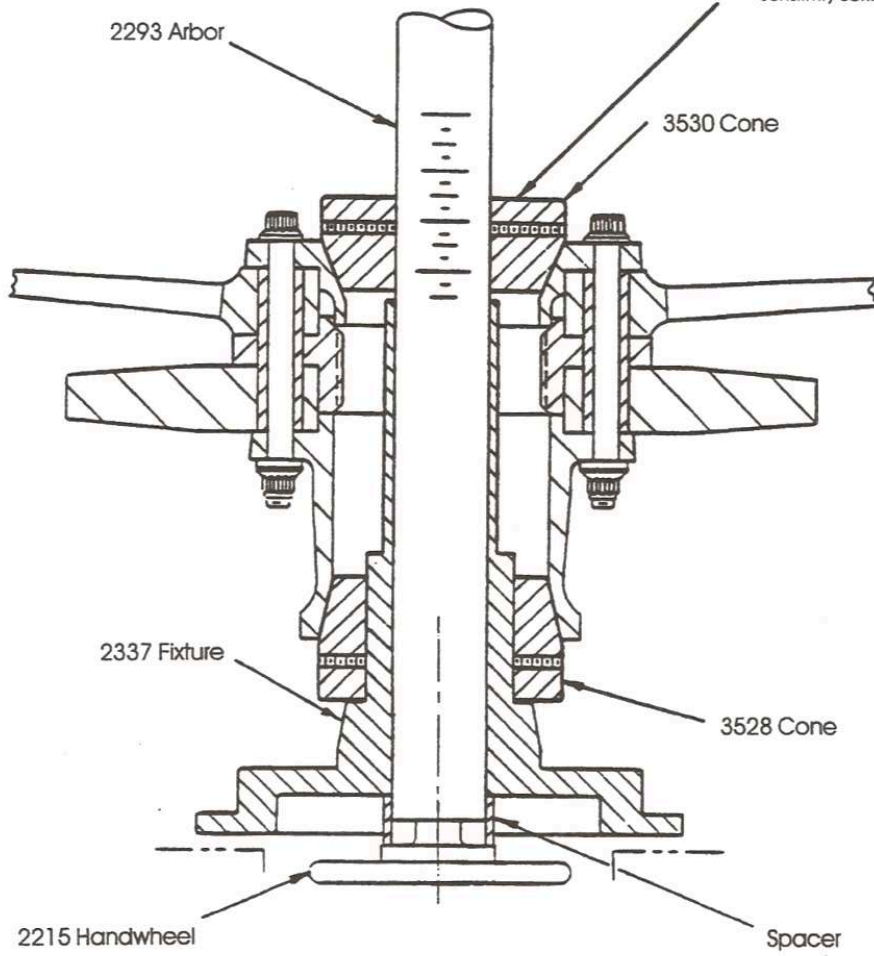

**BELL MODEL 412
MAIN ROTOR HUB AND BLADE BALANCE
BALANCE RECORD**

ROTOR HUB PART NO. 412-010-100-115 SERIAL _____

ROTOR BLADE PART NO. 412-015-200-101

WEIGHT	SERIAL	POSITION
"	"	<u>RED</u>
"	"	<u>BLUE</u>
"	"	<u>ORANGE</u>
"	"	<u>GREEN</u>

CORRECTION WEIGHT OUNCE

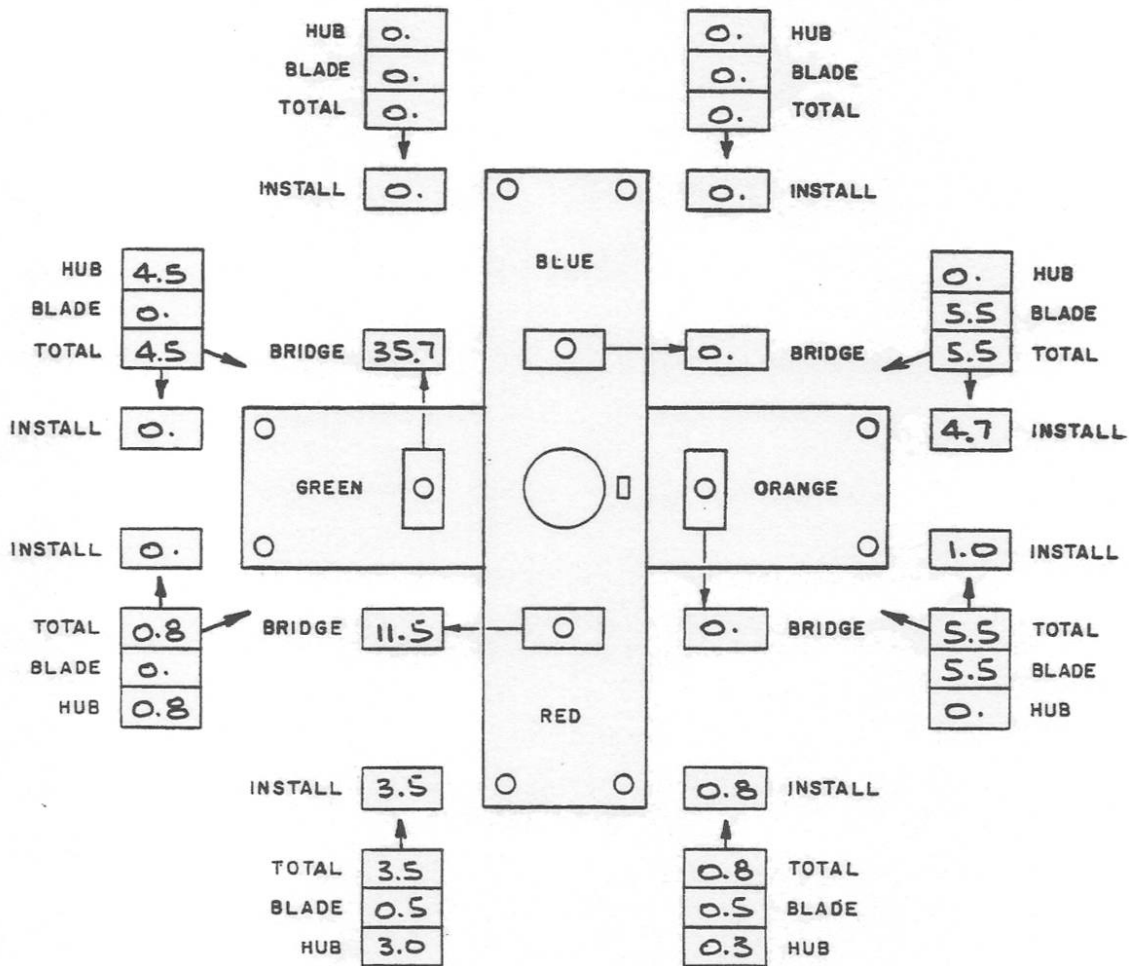

**BELL MODEL 412
MAIN ROTOR HUB AND BLADE BALANCE
BALANCE RECORD**

ROTOR HUB PART NO. 412-010-100-115 SERIAL _____
 ROTOR BLADE PART NO. 412-015-200-101

WEIGHT	SERIAL	POSITION
_____	_____	<u>RED</u>
_____	_____	<u>BLUE</u>
_____	_____	<u>ORANGE</u>
_____	_____	<u>GREEN</u>

CORRECTION WEIGHT OUNCE

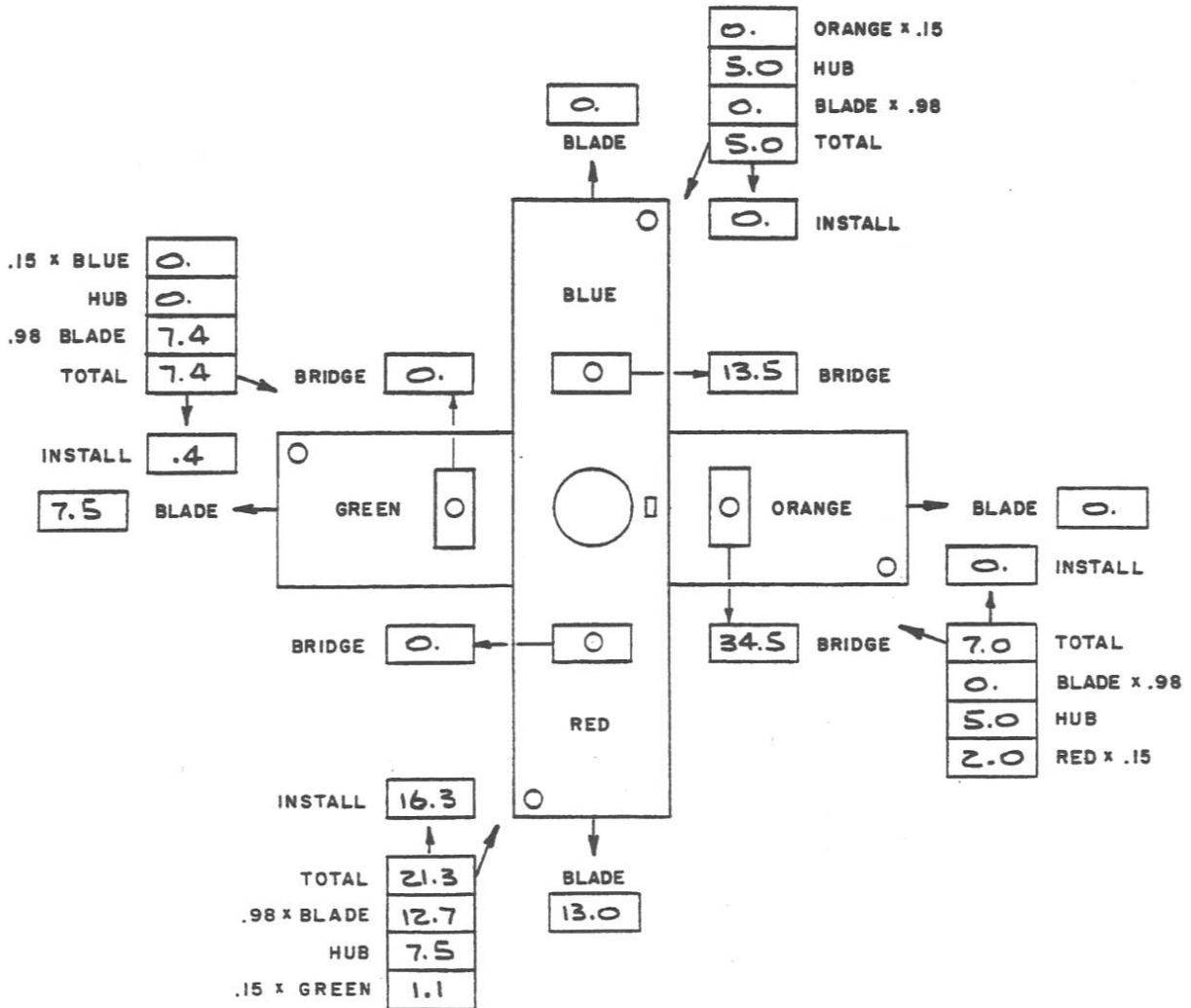

**Main Rotor Balance Correction Determination
- Typical -**